

Show:

Judge:

Novice Level

Breed:

No.:

Date:

Sequence #1: Back Left Heel

- K. Left Heel to I
- I. Back Left Heel to D
- D. Left Heel to F
- F. Back Left Heel to W

Heeling forward requires a brisk pace. The backward heeling pace may be a bit slower. Make smooth transitions with minimal hesitations when changing directions. Pivot 90° at F and step back for a smooth transition. At W, halt at a stand or with a sit in heel position.

Point Value

10

Points Awarded

Sequence #2: Circle

- W. Right Heel to L
- L. Circle twice at L, Right Heel to S
- S. Left Heel to X
- X. Circle twice at X, Left Heel to F

When reaching L, prepare for circling before stopping, so dog can continue moving from heeling to circling. Be ready to step off into heel as dog completes the second revolution of the circle, so there is no hesitation between circling and heeling. At S, turn right into the dog to put it in left heel position and proceed as above for circling at X and heeling to F. Halt with dog in a stand or sit in heel position.

Point Value

20

Points Awarded

Sequence #3: Back Up / Paws On

- F. Left Heel to X
- X. Come Front, Paws On-Right 3 times
- X. Front Forward to M
- M. Back up to X
- X. Paw On-Left 3 times

When reaching X, the handler stops while the dog comes to front and sits to perform the Paws On. Then the handler pivots slightly to the right to back to M as the dog moves forward to M. At M, there is a smooth transition as the dog moves backwards and the handler moves forward to X, where the dog sits to perform the Paws On.

Point Value

20

Points Awarded

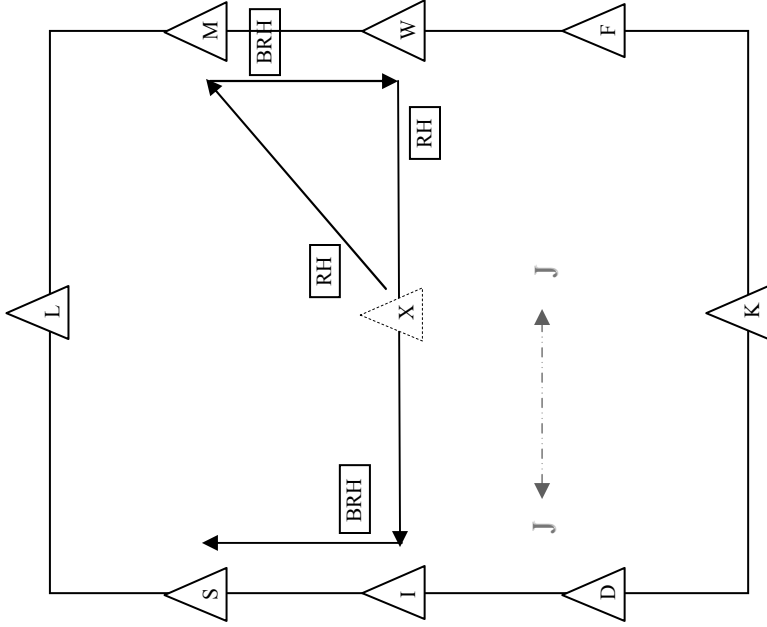

Sequence #4: Back Right Heel

- X. Right Heel to M
- M. Back Right Heel to W
- W. Right Heel to I
- I. Back Right Heel to S

Heeling forward requires a brisk pace. The backward heeling pace may be a bit slower. Make smooth transitions with minimal hesitations when changing directions. Pivot 90° at I and step back for a smooth transition. At S, halt at a stand or with a sit in heel position.

Point Value

10

Points Awarded

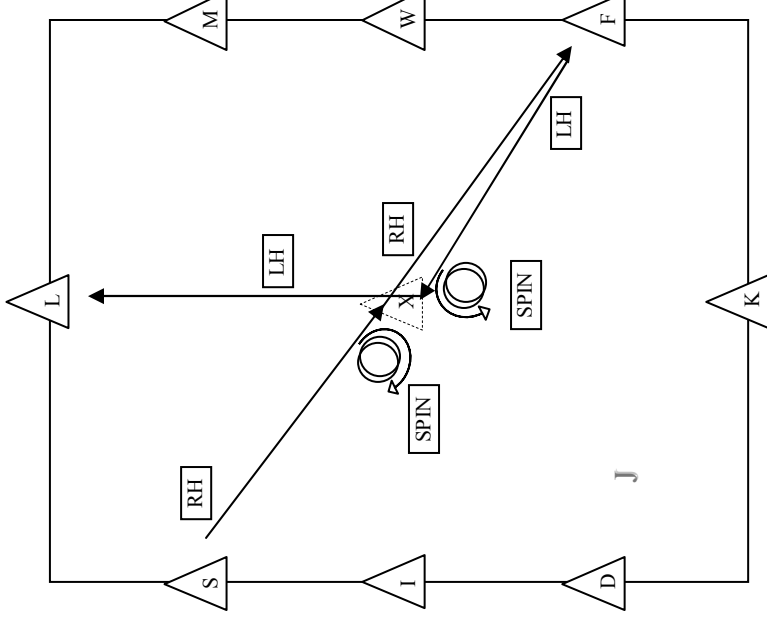

Sequence #5: Spin

- S. Right Heel to X
- X. Spin (2 turns) at X, Right Heel to F
- F. Left Heel to X
- X. Spin (2 turns) at X, Left Heel to L

When reaching X, prepare for spinning before stopping, so dog can continue moving from heeling to spinning. Be ready to step off into heel as the dog completes the second revolution of the spin, so there is no hesitation between spinning and heeling. At F, right turn into the dog to put it in left heel position and proceed as above for spinning at X and heeling to L. Halt with dog in stand or sit in heel position.

Point Value

20

Points Awarded

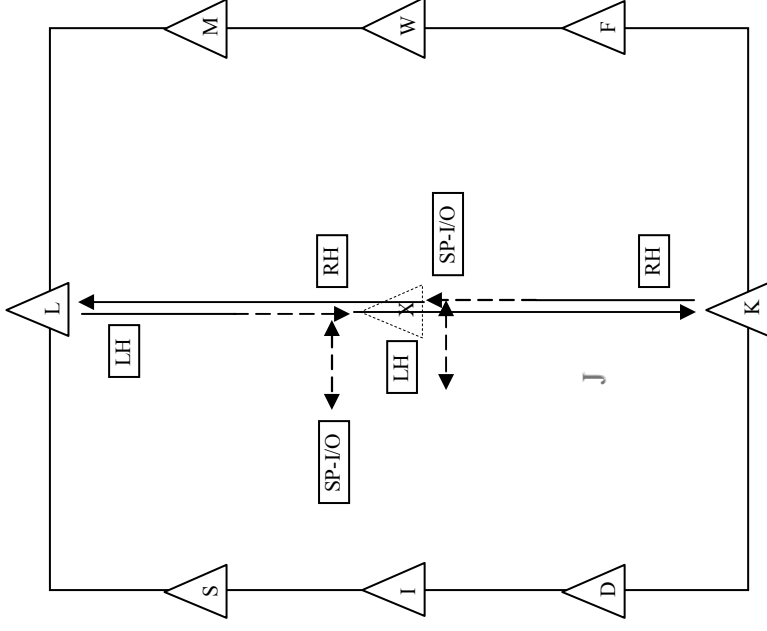

Sequence #6: Side Pass

- L. Left Heel, slow Left Heel to X
- X. Side Pass In/Out (3), Left Heel to K
- K. Right Heel, slow Right Heel to X
- X. Side Pass In/Out (3), Right Heel to L

Begin at a normal pace. At about halfway to X, slow to glide into the side pass to the right (In), then immediately switch to the left (Out) and side pass back to X. The dog may be slightly behind heel position while side passing, but not when heeling to K. At K, turn left into the dog to put it in right heel position and proceed as before for side passing at X and heeling to L. Halt in heel position.

Point Value

20

Points Awarded

Bow/Salute (Yes/No)

Total Points Awarded

Beginning On-Leash

Novice Off-Leash

Course Place