

**Sequence #1: Heel Back Turn - Left**

K Left Heel to I  
 I. Heel Back Turn, Back L Heel to D  
 D. Heel Back Turn, Left Heel to F  
 F. Heel Back Turn, Back L Heel to W  
 W. Heel Back Turning

When reaching I, pivot left into the dog so that it circles backwards  $\frac{3}{4}$  of a turn, and continue heeling backwards at Left Heel to D. At D, pivot into the dog again to perform another  $\frac{3}{4}$  backward circle in heel position, and then Left Heel forward to F. At F, another  $\frac{3}{4}$  pivot/backward circle and continue to heel backwards at Left Heel to W. At W, the dog heels backwards in a full circle as the handler pivots left into the dog. Halt at Heel.

**Point Value**  **Points Awarded**

**Sequence #2: Circle Away**

W. Right Heel fast pace to L  
 L. Circle once, Right Heel to X  
 X. Circle Away, Right Heel to K  
 K. Left Heel to X  
 X. Circle Away, Left Heel fast to F  
 F. Circle once

Run in Right Heel to L. Slow to a normal pace several steps before the dog circles. As dog circles into heel position, proceed to X. At X, the dog performs the Circle Away and continues Right Heel to K, where the handler turns right into the dog to put it in left heel position. Proceed to X and Circle Away at X. As the dog returns to heel position, run in Left Heel to F and slow to a normal pace as the dog circles at F. Halt at heel.

**Point Value**  **Points Awarded**

**Sequence #3: Back Away / Paws Alt.**

F. Back Up (3) / Back Away to X  
 X. Stand Front, Paws Alt. (3)  
 X. Front Forward to M  
 M. Back Up (3) / Back Away to X  
 X. Sit in Right Heel, Paws Alt. (3)

Handler takes 3 steps toward backing dog, then stops and sends dog away to X. After the dog reaches X, the handler walks to the dog and they perform the Paws Alternating with the dog standing in front position. Then the handler pivots slightly to the right and backs to M as the dog moves forward to M. Repeat back up/back away sequence. At X, handler walks around to dog's left side, cues a sit in right heel position, and then performs the Paws Alternating. Either paw may be lifted first.

**Point Value**  **Points Awarded**

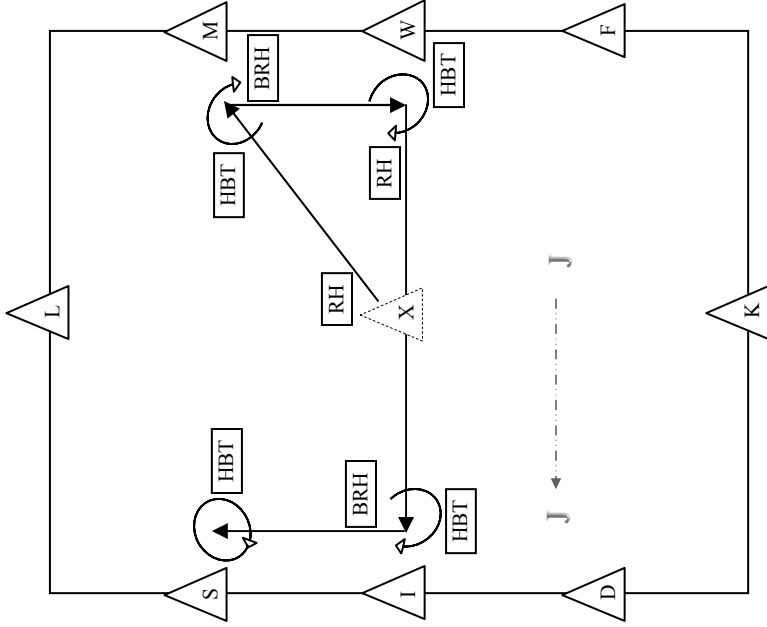

**Sequence #4: Heel Back Turn - Right**

- X. Right Heel to M
- M. Heel Back Turn, Back Rt Heel to W
- W. Heel Back Turn, Right Heel to I
- I. Heel Back Turn, Back Rt Heel to S
- S. Heel Back Turning

When reaching M, pivot right into the dog so that it circles backwards  $\frac{3}{4}$  of a turn, and continue heeling backwards at Right Heel to W. At W, pivot into the dog again to perform another  $\frac{3}{4}$  backward circle in heel position, and then Right Heel forward to I. At I, another  $\frac{3}{4}$  pivot/backward circle and continue to heel backwards at Right Heel to S. At S, the dog heels backwards in a full circle as the handler pivots right into the dog. Halt at Heel.

**Point Value**  **Points Awarded**

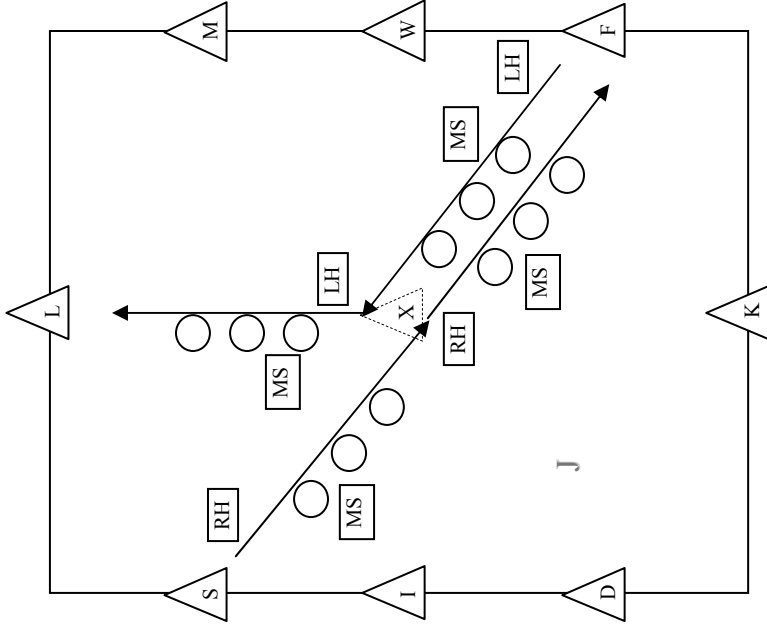

**Sequence #5: Moving Spins**

- S. Right Heel, 3 Moving Spins to X
- X. Right Heel, 3 Moving Spins to F
- F. Left Heel, 3 Moving Spins to X
- X. Left Heel, 3 Moving Spins to L

Handler starts at a normal pace, but slows for the three spins, then resumes the normal pace through X, and slows again for 3 more spins before reaching F. At F the handler turns right into the dog to put the dog in left heel position. Repeat the heeling pace for the Moving Spins, but at X, the handler turns slightly to the right to continue toward L. Halt at Heel.

**Point Value**  **Points Awarded**

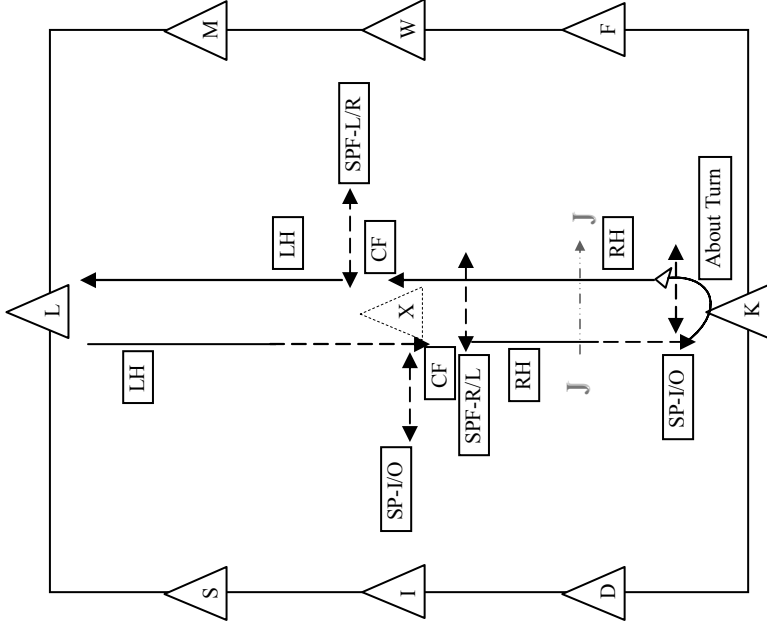

**Sequence #6: Side Pass Front**

- L. Left Heel, slow Left Heel to X
- X. Side Pass I/O (3), Come Front
- X. Side Pass Front R/L (3), R Heel to K
- K. Side Pass I/O (3), Right Heel to X
- X. Come front, Side Pass Front L/R (3)
- X. Left Heel to L

Begin at a normal pace. At about halfway to X, slow to glide into side passing to the right and back to the left at X. Then the dog comes to the front position for side passing. The dog falls into the right heel position as handler moves forward at normal pace. Slow pace to glide into the side pass at K. About turn, and Right Heel to X. At X, dog repeats Come Front and Side Pass, and then falls into Left Heel as the handler proceeds at a normal pace to L. Halt at Heel.

**Point Value**  **Points Awarded**

Bow/Salute (Yes/No)

Total Points Awarded

Course Place